



DO IT RIGHT



CONTROL EQUIPMENT VARIABLE SPEED DRIVE

2021 V1

VARIABLE SPEED DRIVE

Frequency Inverter



220V single phase/380V three phase/525 three phase

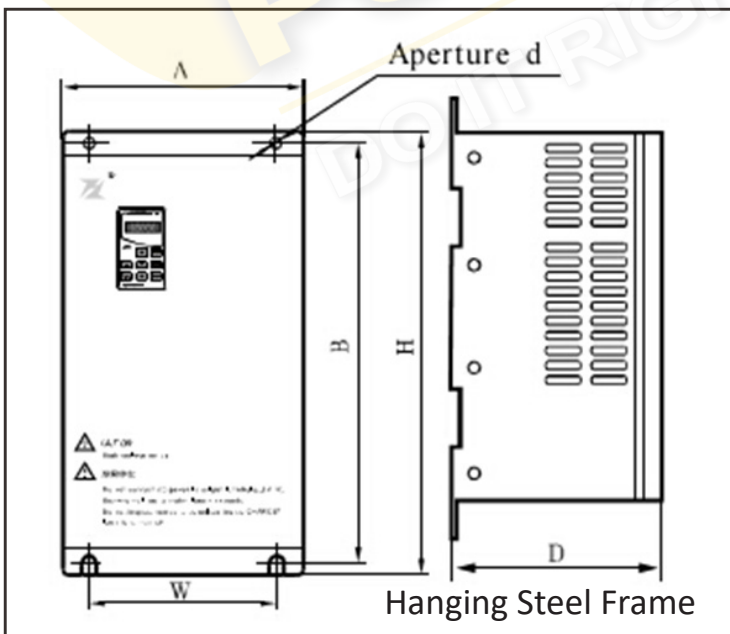
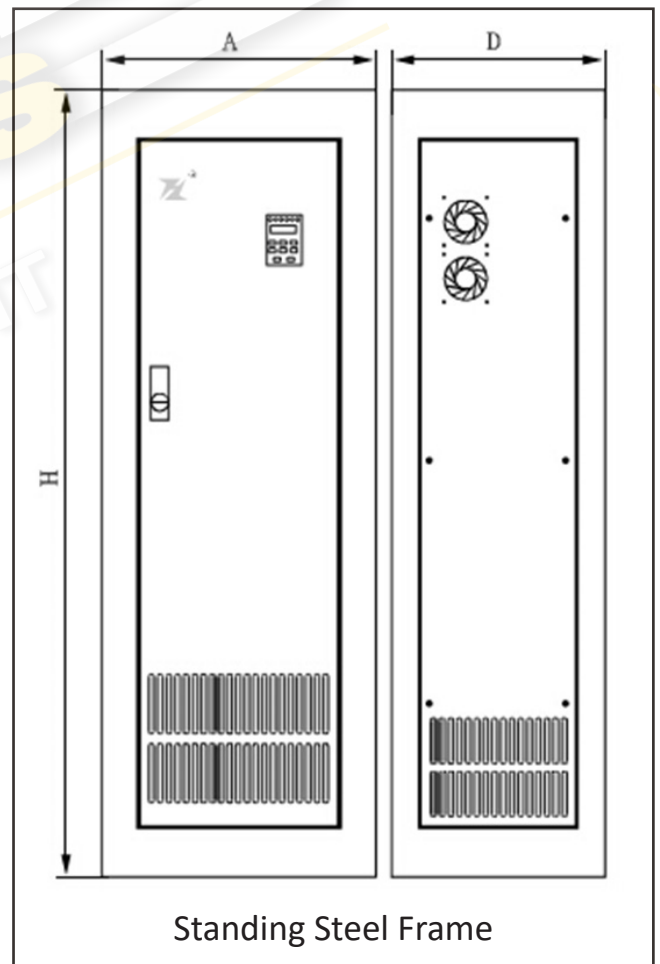
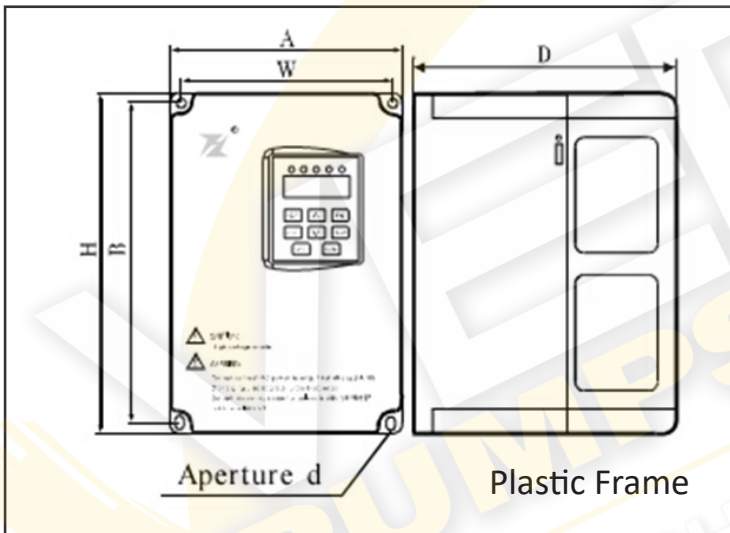
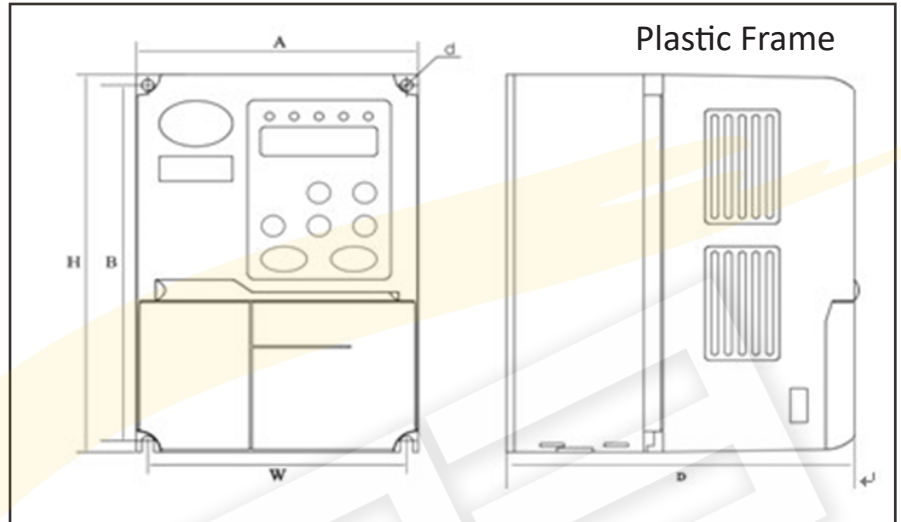

Model name breakdown

F3053 - F 0007 L 2 3

- 1: Single phase output 3: Three phase output
- Input voltage: 2-220V 4-380V
- Freq. range: L: 0 - 400Hz
- Applicable motor: 0007 is 7.5kW, 0015 is 1.5kW
- Series: F - intelligent water pump controller
- Series Name

Dimensions

SERIES	CASE	MODEL	POWER ADAPTER (KW)	SIZE (MM)					
				A	B	H	W	D	d
F3053	302	F2/3053F0040L43	4.0	147.4	236	250	160	194.5	5.0
		F2/3053F0040L53	4.0						
		F2/3053F0055L43	5.5						
		F2/3053F0075L43	7.5						
		F2/3053F0075L53	7.5						
	305	F2/3053F0007L21	0.75	110	169.6	179.6	120.1	150.3	4.0
		F2/3053F0015L21	1.5						
		F2/3053F0022L21	2.2						
		F2/3053F0007L43	0.75						
		F2/3053F0015L43	1.5						
		F2/3053F0022L43	2.2						
		F2/3053F0030L43	3						
	317	F2/3053F0022L53	2.2	110	169.6	179.6	120.1	150.3	4.0
		F2/3053F0110L43	11.0	205.6	303.6	322	220	193.5	6.0
		F2/3053F0150L43	15.0						
		F2/3053F0185L43	18.5	175	455	472	295	222	6.5
		F2/3053F0110L53	11.0	205.6	303.6	322	220	193.5	6.0
	F2/3053F0150L53	15.0							
	030	F2/3053F0220L43	22.0	175	455	472	295	222	6.5
		F2/3053F0300L43	30.0						
		F2/3053F0370L43	37.0	230	564.5	580	380	270	7.0
		F2/3053F0185L53	18.5	175	455	472	295	222	6.5
		F2/3053F0220L53	22.0						
		F2/3053F0300L53	30.0						
F2/3053F0370L53	37.0								
045	F2/3053F0450L43	45.0	230	564.5	580	380	270	7.0	
	F2/3053F0450L53	45.0							

VARIABLE SPEED DRIVE

Frequency Inverter



Selection table

VOLTAGE	MODEL	OUTPUT POWER (kW)	APPLICABLE MOTOR (HP)	RATED CURRENT (A)
(1PH - 3PH) 220V	F0007L23	0.75	1	4.1
	F0015L23	1.5	2	7.0
	F0022L23	2.2	3	10.0
	F0030L23	3.0	4	13.0
(3PH - 3PH) 380V	F0007L43	0.75	1	2.5
	F0015L43	1.5	2	3.7
	F0022L43	2.2	3	5
	F0030L43	3	4	6.5
	F0040L43	4	5	9.5
	F0055L43	5.5	7	12.5
	F0075L43	7.5	10	17.5
	F0110L43	11	15	24
	F0150L43	15	20	33
	F0185L43	18.5	25	40
	F0220L43	22	30	46
	F0300L43	30	40	58
	F0370L43	37	50	80
	F0450L43	45	60	91
(3PH - 3PH) 525V	F0022L53	2.2	3	3.6
	F0040L53	4	5	6.9
	F0075L53	7.5	10	14
	F0110L53	11	15	19.2
	F0150L53	15	20	26.4
	F0185L53	18.5	25	32
	F0220L53	22	30	36.8
	F0300L53	30	40	46.4
	F0370L53	37	50	64
	F0450L53	45	60	72.8

ITEM		SPECIFICATIONS
Control Model		SPWM
Input		220V: 220±15%; 380V: 380±15%; 525V: 525±15%
Output Voltage		0~input voltage
5-Digit Display & Status Indicator light		This shows frequency, current, speed, voltage, set pressure, current pressure, fault and so on
Communication Control		RS-485
Operating Temperature		-10~40°C
Ambient Humidity		0-95% relative humidity (non-condensing)
Vibration		<0.5G
Frequency Control	Range	0.10~400.0Hz
	Setting Resolution	Digital: 0.1Hz; Analogue: 1% maximum frequency
	Output Resolution	0.1Hz
	Keyboard Setting Mode	Set by up/down keys
	Analogue Setting Mode	External voltage 4-20mA, 2-10V
	Other Functions	Frequency limits, running frequency, frequency stop, three adjustable carrier frequencies can be set separately
Protection Function	Overload	Electronic relay protection motor drive (for constant torque 150%/1min)
	Low Voltage	220V: DC Voltage<200V; 380V: DC Voltage<350V; 525V: DC Voltage<472V
	High Voltage	220V: DC Voltage>242V; 380V: DC Voltage>420V; 525V: DC Voltage >578V
	Instant Stop and Restart	Restarted by frequency track after instantaneous stop
	Stall Prevention	Anti-stall during acceleration/deceleration run
	Output short circuit	Electronic circuit protection
	Other functions	Fin over-heating protection, restriction of reverse running, direct start after power on, fault reset, parameter lock PID, one-drive-more, etc.

PARAMETERS & FUNCTIONS

F3053



CODE	FUNCTION	DETAILS	FACTORY SETTING
F-000	User password	0~65535	Consult supplier
F-001	Parameter limited	0~250	237
F-002	Base frequency	0~400HZ	50HZ
F-003	Base voltage	0~255/0~440V	220/380/525V
F-004	Frequency upper limit	0~400HZ	50HZ
F-005	Frequency lower limit	0~50HZ	25HZ
F-006	Corresponding pressure of sensors	0~200Bar	10/16/25Bar
F-007	Rated current of motor	1--*(A)	according to the motor nameplate
F-008	Control function	0~10000 <div style="display: flex; justify-content: space-around; border: 1px solid black; padding: 2px;"> Bit5 Bit4 Bit3 Bit2 Bit1 </div> Bit1=0: auxiliary inverter 1: master inverter 2: master inverter of small pump Bit 2=1: start/stop key valid on panel Bit 3=0: low water level/pressure detected opened valid 1: low water level/pressure detected closed valid Bit 4 - running order 0: panel 1: external terminals 2: reserve 3: auto start when power is on Bit 5 - motor rotation 0: run as chosen 1: run in opposite direction	03011/13011 depending on direction of rotation.
F-009			N/A
F-010			N/A
F-011	Parameter reset	Pump station reset ABC C: current pump station B: total number of pump stations	0
F-012	Acceleration time of PID	0.1~6500s	2s
F-013	Deceleration time of PID	0.1~6500s	2s
F-014	Rated max. head of pump	0~250m	as per performance curve
F-015			N/A

CODE	FUNCTION	DETAILS	FACTORY SETTING
F-016	Water supply mode	<div style="display: flex; justify-content: space-around; border: 1px solid black; padding: 2px;"> Bit5 Bit4 Bit3 Bit2 Bit1 </div> <p>Bit1 - PID feedback channel selection 0: AVI/AI(0~10V) set 1: AI/AI(4~20mA) set Bit 2 - sleep signal selection 0: select the internal sleep signal 1: select the external sleep signal 2: automatic Bit 3 - reserve Bit 4 - display decimal places 0: show a decimal 1: show two decimals Bit 5 - check the pump fault 0: valid 1: invalid</p>	01121
F-017	PID digital given	% of system pressure to transducer rating	e.g. 6Bar (system) / 10Bar (transducer) = 60%
F-018	PID select given	0: set by operator panel 1: set by analogue	0
F-019	Accelerated time of starting	6500s	10s
F-020	Version	133.1/5283/6053	N/A
F-021	Integral time (I)	3600s	1s
F-022	Motor speed as zero flow	0~99%	5%
F-023	Wake up level offset	0-25m (below duty point)	20
F-024	Sleep frequency	0-50Hz	26Hz
F-025	Detecting time of sleep frequency	0~5s	1s
F-026	Reserved		
F-027	PID break detection level	0~100s	0.3s
F-028	PID break detection time	0~100s	10s
F-029	Total number of pumps in system	1: single pump 2-8: multi-pumps	1

CODE	FUNCTION	DETAILS	FACTORY SETTING
F-030			N/A
F-031			N/A
F-032			N/A
F-033			N/A
F-034			N/A
F-035			N/A
F-036	Under pressure alarm time	0~6000s	0
F-037	Zero offset of sensor	0-----100%	0
F-038	Detection time of lack of water	0~6500s	
F-039	Protection point of high pressure of discharge water	0~200%	80%
F-040	Protection point of low pressure of discharge water	0~200%	3%
F-041	Delay of protection and recovery of high pressure discharge water	0~6500s	60s
F-042	Delay of protection of low inlet water level	0~50s	0
F-043	Delay of recovery of low inlet water level	0~50s	0
F-044	Inspect interval time	0.1~65535min	0
F-045	Inspect working time	0.1~3600s	0
F-046	Inspect frequency	0.1~50HZ	10HZ
F-047	No load current protection	0~100%	90%
F-048	Relief pressure value	0.1~10Bar	1Bar

CODE	FUNCTION	DETAILS	FACTORY SETTING
F-050	Multi-function input FWD	00: invalid	1
F-051	Multi-function input REV	01: RUN	0
F-052	Multi-function input S1	04: stop	01/31
F-053	Multi-function input S2	05: FWD/REV	0
F-054	Multi-function input S3	06: JOG	29
F-055	Multi-function input S4	07: JOG forward	0
F-056	Multi-function output 1 (MO1)	08: JOG reverse	1
F-057	Multi-function output 2 (MO2)	09: emergency stop	5
F-058	Multi-function output 3 (RA/RB/RC)	10: reset	15
F-059	Multi-function output 4 (MA/MB/MC)	11: reserve	2
		12: cooling or motor overheating	
		13: high water level	
		14: low water level	
		15: master inverter ordered	
		18: compulsion awake	
		19: compulsion speed mode	
		20~28: reserve	
		29: low water level detection (connect valid)	
		30: low water level detection (disconnect invalid)	
		31: force lack of water detection	
		0: invalid	
		1: running	
		2: fault indication	
		5: relief pressure output	
		10: alarm of inverter overload	
		11: alarm of motor overload	
		12: alarm of over torque	
		13: alarm of low voltage	
		14: reserve	
		15: faulty output	
		16: faulty output	
		20: 4~20mA break	
		25~27: reserve	
		28: alarm of PID lower limit	
		29: alarm of PID upper limit	
		30: cooling of fan work	

FAULT FINDING F3053



CODE	FUNCTION	CORRECTION
E.2.P	External lack of water protection	Check that the water probe is functioning. Ensure that connection and terminal is normal. Check that parameter is correct.
E.3.P	Internal lack of water protection (function begins at 1507)	Press the 'stop' button to reset
EE.01P	System electric power is insufficient (function begins at 1507)	Check if power voltage is low Check if wire size is too small Check if power supply is insufficient
EE1P	Spare pressure transmitter faulty (function begins at 1507)	Replace transmitter if it is broken. Correct wiring of transmitter if incorrect. Tighten loose wiring. Confirm that communication between pumps is normal.
E.11	Working time limit	Time limit after running 1hour. Check with technician for details.
E.H.B	Alarm of high water level (function begins at 1507)	Check if high water level detector is normal. Confirm that wiring and terminal are correct. Check if parameters are correct.
E.L.B	Alarm of low water level	Check if low water level detector is normal. Confirm that wiring and terminal are correct. Check if parameters are correct. Confirm that inlet is fine. Check motor rotation.
EE21	Detect no pressure transmitter signal (function begins at 1507)	Check transitter's wiring.
E.L.P	Alarm of low pressure	Check if feedback pressure is lower than low pressure protection value.
E.H.P	Alarm of high pressure	Check if feedback pressure is higher than high pressure protection value.
E5P	Alarm of under pressure	Check if pipe pressure is normal.
EEPn	Alarm of broken pump	Check the water pumps.
E.1P	Alarm of PID break detection	The standard of the feedback pressure. The set range from 0-100% when the feedback pressure is under the value of F027, even later than the time of F028, it will show as 'E.1P'. Please check the water inlet, connection of pressure transmitter, the rotation of pump motor and if there is air in the pump. Note: If F027/028=0, the alarm will be invalid.
E04.D/E24.D	Over-current during ramp-up	Check whether the motor has experienced a short circuit or partial short circuit and whether the insulation of output wire is good. Extend the ramp-up and ramp-down time. The configuration of the inverter is not reasonable. The inverter's capacity should be increased.
E04.P/E24P	Over-current at constant speed	
E04.B/E24B	Over-current at deceleration	
E04.H	Over-current at stop	Check for motor damage. Alternatively, the inverter has failed. Please send it to the factory for repair.
E02.H/D E02.P/B	Over voltage	Extend the ramp-down time or add a braking resistor. Improve the main supply voltage and check whether there is any sudden change in the voltage.
E01.H/D E01.P/B	Low voltage	Check if the input voltage is normal. Check if there is sudden change in load. Check if there is a missing phase.
E0H.H/D E0H.P/B	Overheating of inverter	Check if the fan is blocked. Check if the ambient temperature is normal.
E07.D E07.P E07.B	Inverter overload 150% per minute	Check if the capacity of the controller is lower. Check if there is any jamming in the mechanical load. Reset the V/F curve.
E08.D E08.P E08.B	Motor overload 150% per minute	The equipped motor is too small. The motor is hot and the insulation poor. Check if there is any missing phase. The mechanical load has increased.
E0F	Parameter setting error	
E5P	Alarm of under pressure	Check if the pipe pressure is normal.

Wiring

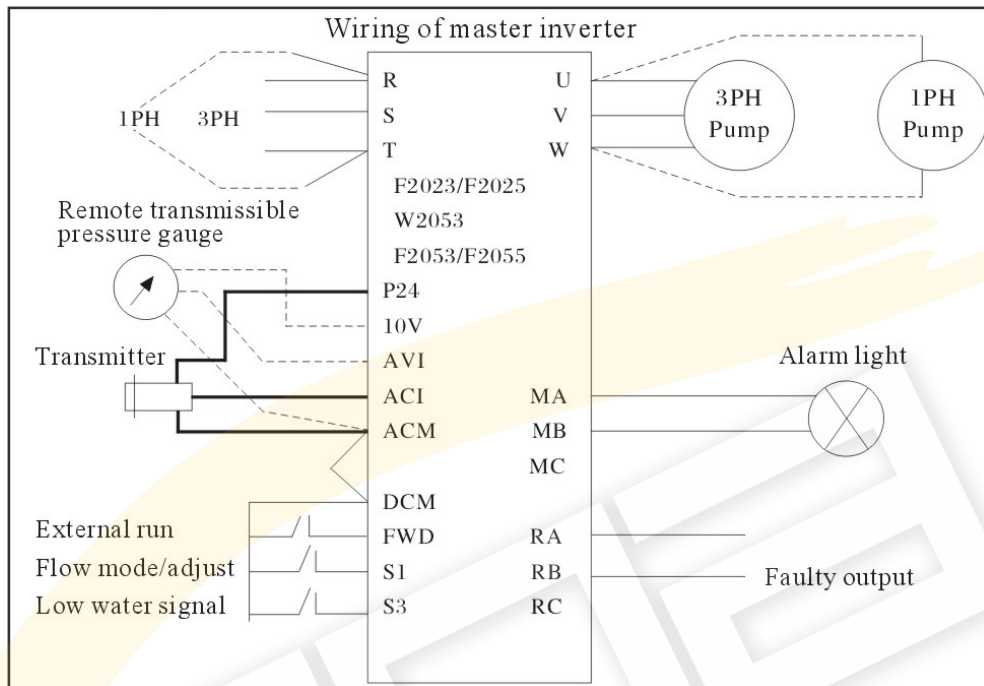

SWITCH DESCRIPTION ON MAIN BOARD:

SW1:  V: 0-10V voltage signal
I: 4-20mA current signal

SW2:  AVI: remote transmissible pressure gauge 0-10V
WR

SW3:  Input polarity optional switch
PNP: Multi-function input terminal (S1-S4), FWD/REV connect to common terminal DCM
NPN: Multi-function input terminal (S1-S4), FWD/REV connect to common terminal EV

Working system

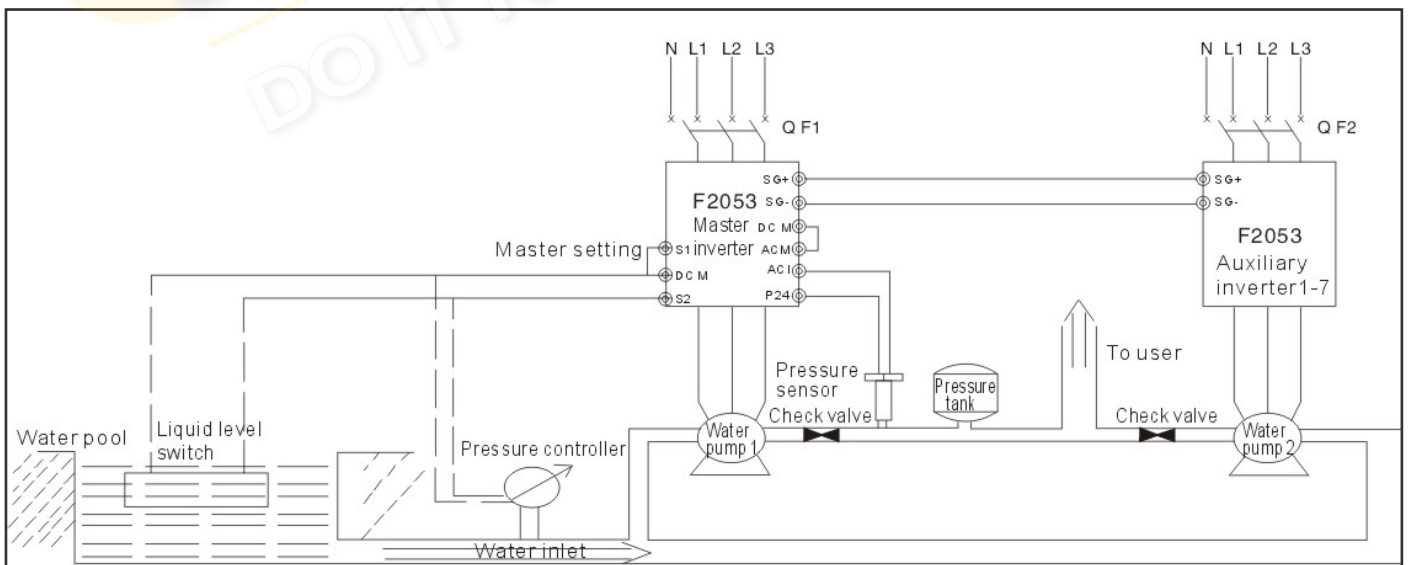

Operator panel

The digital keypad includes two parts: the display panel and keypad.

The display panel displays the parameters and shows the operation status of the AC drive and the keypad provides a programming and control interface.



Button	Name	Parameter step 1	Parameter step 2
PROG	Programming	Enter or quit from parameter setting	
DATA	Confirm	Parameter no. confirm	Parameter value confirm
▲	Increase	Parameter no. increase	Parameter value increase
▼	Decrease	Parameter no. decrease	Parameter value decrease
RUN/STOP	RUN/STOP	Shift parameter no	Parameter value shift
Button	Name	Pressure mode	Water flow mode(adjust)
PROG	Programming	Enter or quit from parameter setting	
DATA	Confirm	Displayed Content	
▲	Increase	Increase of set pressure	Increase of set flow
▼	Decrease	Decrease of set pressure	Decrease of set flow
RUN/STOP	RUN/STOP	RUN/STOP	



Model selection

		SYSTEM PARAMETERS		
		0-10Bar	0-16Bar	0-25Bar
RECOMMENDED MODEL	10Bar	X		
	16Bar		X	
	25Bar			X

Specifications

Accuracy:	0.5%FS; 1%FS
Nonlinearity:	Full span x 0.2%
Repeatability:	Full span x .05%
Output:	4-20mA (two wire), 0-5V, 0-10V (three wire); 2mV/V, 3.3mV/V (PTS-210)
Input voltage:	24(12~36)VDC (Amplifying signal), 10(6~12)VDC (mV output)
Operating temperature:	-40~800C
Compensated temperature:	0~700C
Overload pressure:	150%FS
Medium material:	Stainless steel
Electric connector:	Hirschman (DIN), M12, 4 pin, Bendix connector, grand cable (custom design)
Process connector:	G1/4, G1/2, 1/2NPT, 1/4NPT, M12*1.5 (custom design)